

HHEAD **o**f **D**DIVISION

(HOD)

LIGHTENING

SAFETY

under

DIRECTOR SAFETY

THE NAME & STYLE
of this most
important **ACTIVITY**



SAFETY LOFTY

ExNoRa

FOCUS

LIGHTENING SAFETY



SAFETY
LOFTY
ExNoRa

FOCUS
**LIGHTENING
SAFETY**

Do this either as a
Subsidiary Organisation (SU)
or as a
Satellite Organisation (SA)



SAFETY LOFTY
ExNoRa

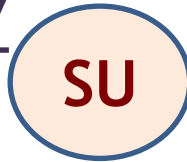

can be a

SUBSIDIARY ORGANISATION
of your parent
ExNoRa INNOVATORS CLUB
of your place /
institution



SAFETY LOFTY
ExNoRa



can be an **INDEPENDENT**

SATELLITE ORGANISATION of
your area / institution
affiliated to
the top body (HQ) of
**ExNoRa INNOVATORS
INTERNATIONAL**



SAFETY LOFTY

ExNoRa

FOCUS

LIGHTENING SAFETY

VERY MUCH PART of

JEEVAN SHASTRA, LIFE SCIENCE,

(जीवन विज्ञान) for

LIVING as HUMAN BEING

MANUSHYA SHASTRA, HUMAN SCIENCE

(मनुष्य विज्ञान) for BEING HUMAN BEING



LIGHTENING SAFETY SAFETY,
a part of
SAFETY LOFTY
SAFETY ExNoRa,
a major division of
YOUR
RWA ExNoRa &
ExNoRa INNOVATORS CLUB
will be captained by an
"Activity Head" :
LIGHTENING SAFETY



Temple Lightening Safety

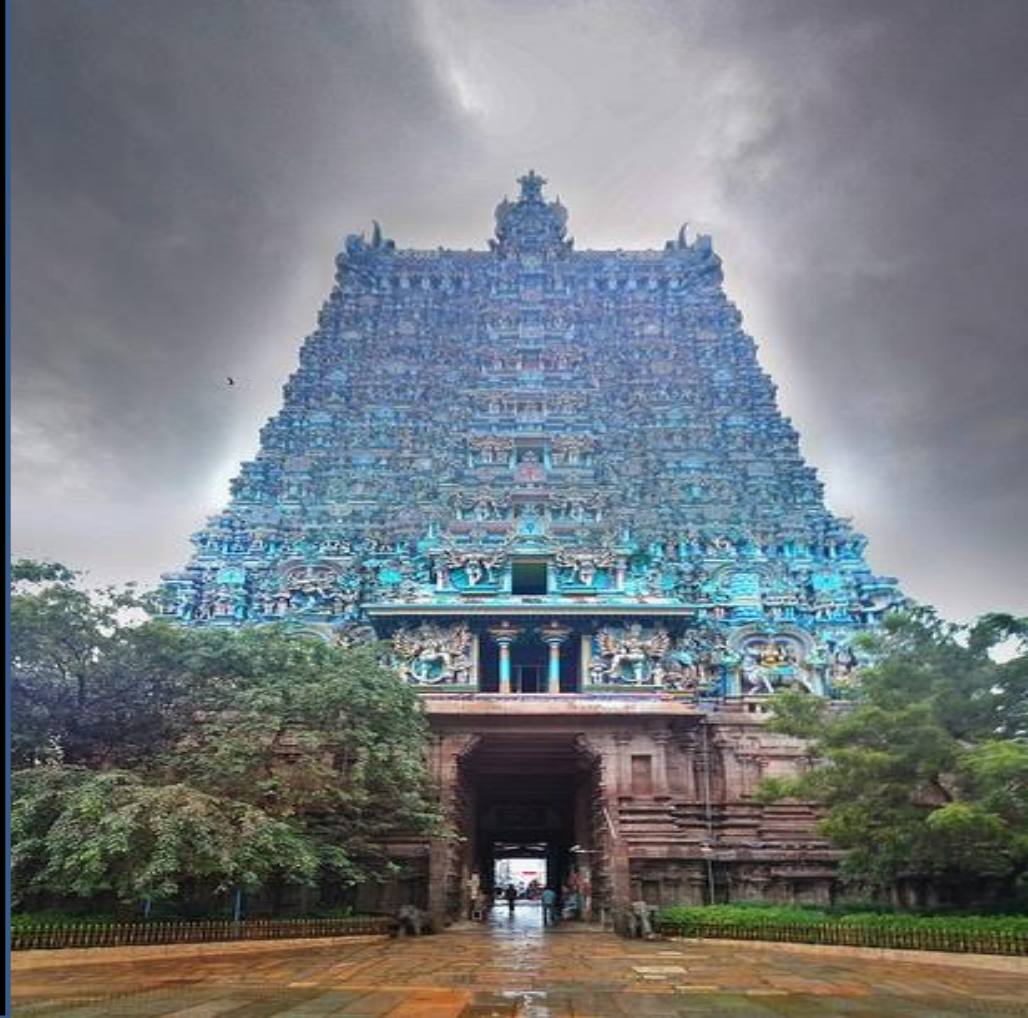

KNOW NOW NATURAL DISASTER LIGHTENING

Lightening can take heavy
toll of LIFE.

In Mugaliwakkam, Tamil
Nadu a lightening struck a
building under construction
that killed 61 & seriously
injured 72 Workers.



A black silhouette of a person with their arms outstretched horizontally, set against a dark blue background filled with glowing, branching lightning bolts in shades of cyan and light blue. The text is centered over the person's torso.

**9 out of 10 lightning strike
victims survive.**

A man with white hair, wearing a yellow and white striped shirt and khaki pants, stands in a field. He is holding a string with a key attached to it, looking up at it. The background is a dark, stormy sky with multiple bright lightning strikes. The text "Lightning strikes 625 people in the US every year." is overlaid on the image in white.

Lightning strikes 625 people
in the US every year.

WHERE MOST LIGHTNING DEATHS OCCUR

54%

Open Fields,
Ball Parks,
Golf Courses

23%

Under
Trees

12%

Beach
& Boats

7%

Operating
Farm
Equipment

4%

Other: Near
Open Windows,
Bicycling, etc.

**When Thunder Roars,
GO INDOORS!**

A photograph of a house at night with a lightning bolt striking the sky above it. The house is silhouetted against the dark sky, with some interior lights visible. A large, bright lightning bolt strikes the sky above the house. The text "When Thunder Roars, GO INDOORS!" is overlaid at the top in yellow, and "Be weather wise" is written in blue cursive at the bottom right.

Be weather wise



LIGHTNING CROUCH

2.  Lightning

Put your feet together, duck your head, and crouch down low in a baseball catcher's stance with hands on knees.



Remove
all metal
objects



BACK



PLAY

STORM SAFETY

HOW TO ESCAPE LIGHTNING ON LAND:

- AVOID BEING THE HIGHEST OBJECT IN THE VICINITY
- NEVER SHELTER UNDER SMALL GROUPS OF (OR SINGLE) TREES
- NO SHELTER? CROUCH, DON'T LIE DOWN FLAT
- IF YOUR HAIR STANDS ON END OR YOU HEAR 'BUZZING' FROM NEARBY ROCKS, FENCES, ETC. MOVE IMMEDIATELY

SWENEWS

Monsoon Awareness Week

Lightning



Safety Tips:

- ⚡ Seek Shelter Indoors
- ⚡ Postpone Outdoor Events

If Caught Outside -

- ⚡ Find A Low Spot, Away From Trees & Fences
- ⚡ Get Off The Water
- ⚡ Leave The Pool



745 AM MDT
Tue Jun 7 2011
National Weather Service
Albuquerque, NM



Lightning Safety

Monsoon Awareness Week: June 9-14



- Lightning is the #2 thunderstorm-related killer
- Lightning can strike several miles away from a storm
- If you hear thunder, move inside a strong building or hardtop vehicle
- Stay clear of trees, power and telephone poles, tall objects
- Stay in shelter for 30 minutes after thunder has ended
- If someone is struck, call for help immediately



Weather.gov/Phoenix

LIGHTENING SAFETY

1. Lightning is an atmospheric discharge of electricity, which typically occurs during thunderstorms, and sometimes during volcanic eruptions or dust storms.
2. During a thunderstorm, Stay away from metal items like pipes, fences, telephone poles and lines even the refrigerator as lightening will find its way into your house through wires and pipes. Don't hold an electrical appliance.
3. Do not take a bath or shower during thunderstorm.
4. Do not stand even near the windows of your house when there is thunderstorm outside. As it can strike you,
5. Do you know people have died because lightening struck when they were talking in the phone. Wireless phones are okay to some extent but still the loud noise of the thunder can damage you err drums through phone.

LIGHTENING SAFETY

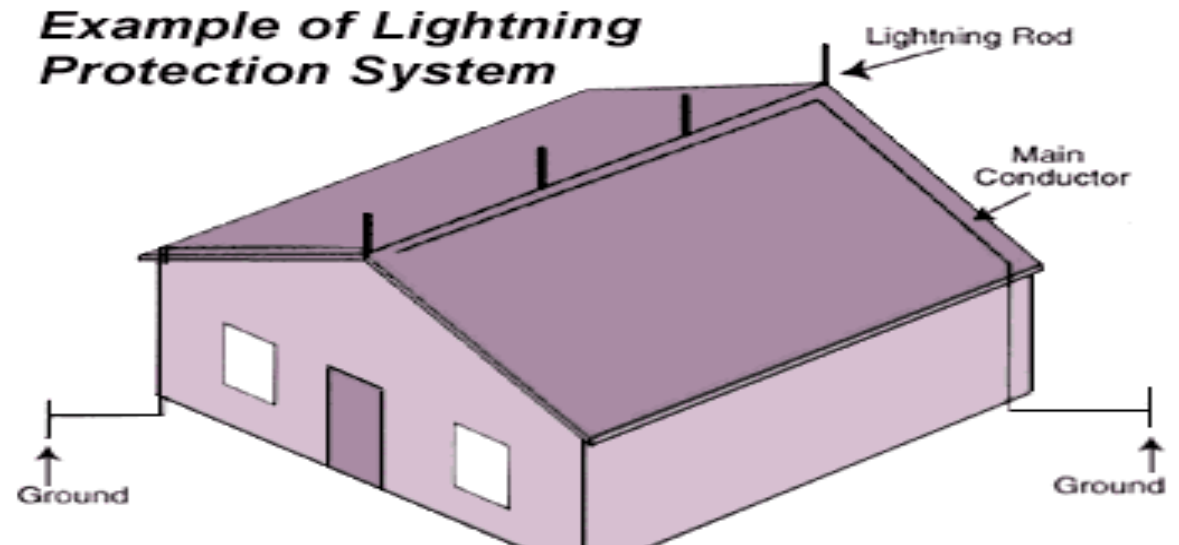

The System

A lightning protection system performs a simple task. It provides a specified path on which lightning can travel. When a home is equipped with a lightning protection system, the destructive power of the lightning strike is directed safely into the ground, leaving the home, family members and personal belongings unharmed. It is important that the cable (wire) that is used **MUST** be braided and be designed specifically for Lightning Protection System installations. Electrical grounding cable should not be used.

The Primary Components

A lightning protection system should include all of the following elements, which work together to prevent lightning damage.

LIGHTENING SAFETY

Air Terminals (Lightning Rods)

Braided Conductor (Cable)

Bonds to metallic bodies

Ground Rods or Ground Plates

Surge Arrestors

LIGHTENING SAFETY Electronic Protection

Modern homes are especially vulnerable to the havoc that lightning can wreak on sensitive electronic equipment.

To assure the highest level of protection, UL-listed lightning surge arrestors are installed on electrical service panels and other incoming lines.

Arrestors are the first line of defense against harmful electrical surges that can enter a structure through power lines.

On the other hand, Lightning rods protect the structure from a direct lightning strike.

LIGHTENING SAFETY LIGHTENING SAFETY

General Design Rules

All buildings must have two groundings as widely separated as possible, preferably at diagonally opposite corners if perimeter distance around the building at ground level is 250 feet or less.

If building perimeter is between 250 feet and 350 feet, then three groundings are required. If building is between 350 feet and 450 feet, then four groundings, etc.

Lightning Protection System shall be applied to metal covered buildings in like manner as on buildings without metal coverings.

Cables shall be free of sharp turns and "u" or "v" pockets. Cables shall remain horizontal or downward path towards the ground.

LIGHTENING SAFETY

Cautions in the Use of Both Copper and Aluminium

Copper equipment shall not be used on aluminium roofs, aluminium sidings, or other aluminium surfaces - including bare galvanized steel.

(Use Aluminium Equipment for these).

Copper and aluminium conductors shall not be interconnected except with acceptable bimetallic connectors

Aluminium equipment shall not be used underground.

Aluminium equipment shall not be used on copper roofing or other copper surfaces.

TYPICAL RESIDENTIAL LIGHTNING PROTECTION SYSTEM

Design Rules: Space rods evenly, no more than 20 feet apart. End rods should be no more than 2 feet from the end (1 foot is typical). Fasten cable every 3 feet. Connect vents and antennas with clamp or lug if within 6 feet of the lightning cable. For a neat job run the down cables next to or behind down spouts, molding, etc. and connect to ground rods (make connections to ground rods or ground plates below ground).

LIGHTENING SAFETY

Location of Chimney Air Terminals

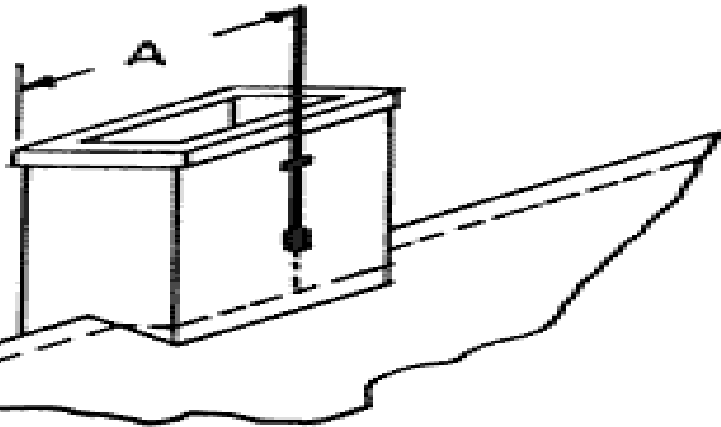

A- No outside corner shall be more than 2 feet from an air terminal

Spacing of Air Terminals

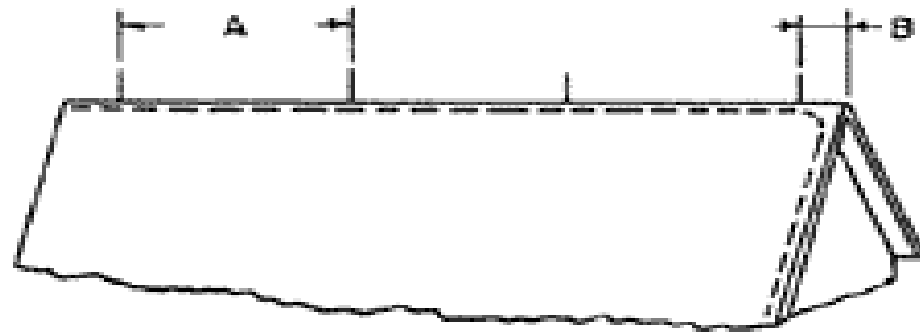

A- 20 foot maximum spacing
B- 2 foot maximum spacing from ridge ends, etc.

Air Terminal Height and Bracing

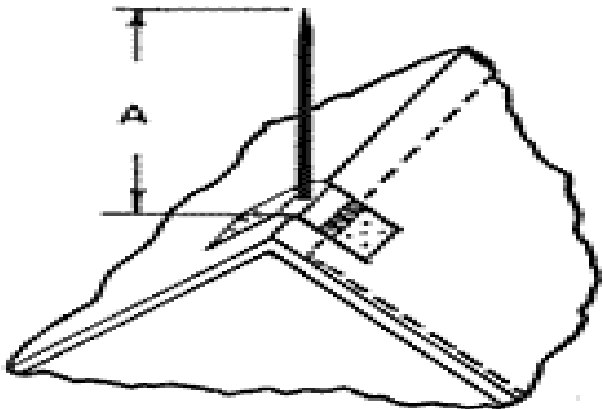

Air terminals shall extend not less than 10 inches above the object to be protected.

Grounding

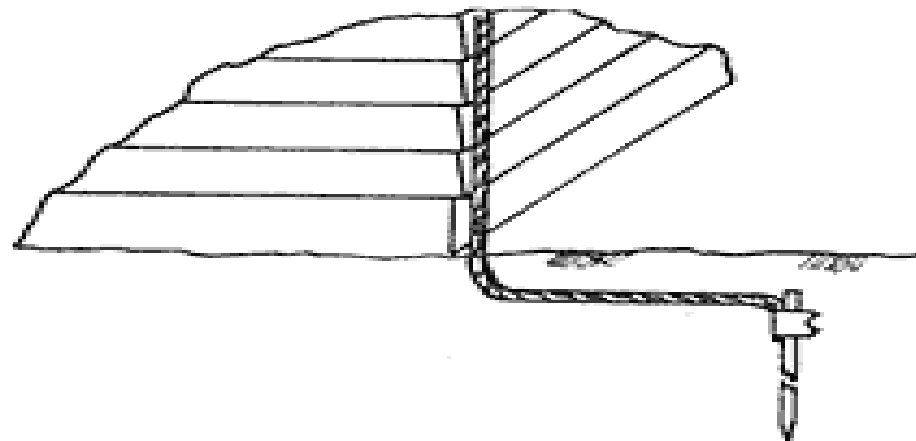

LIGHTNING SAFETY

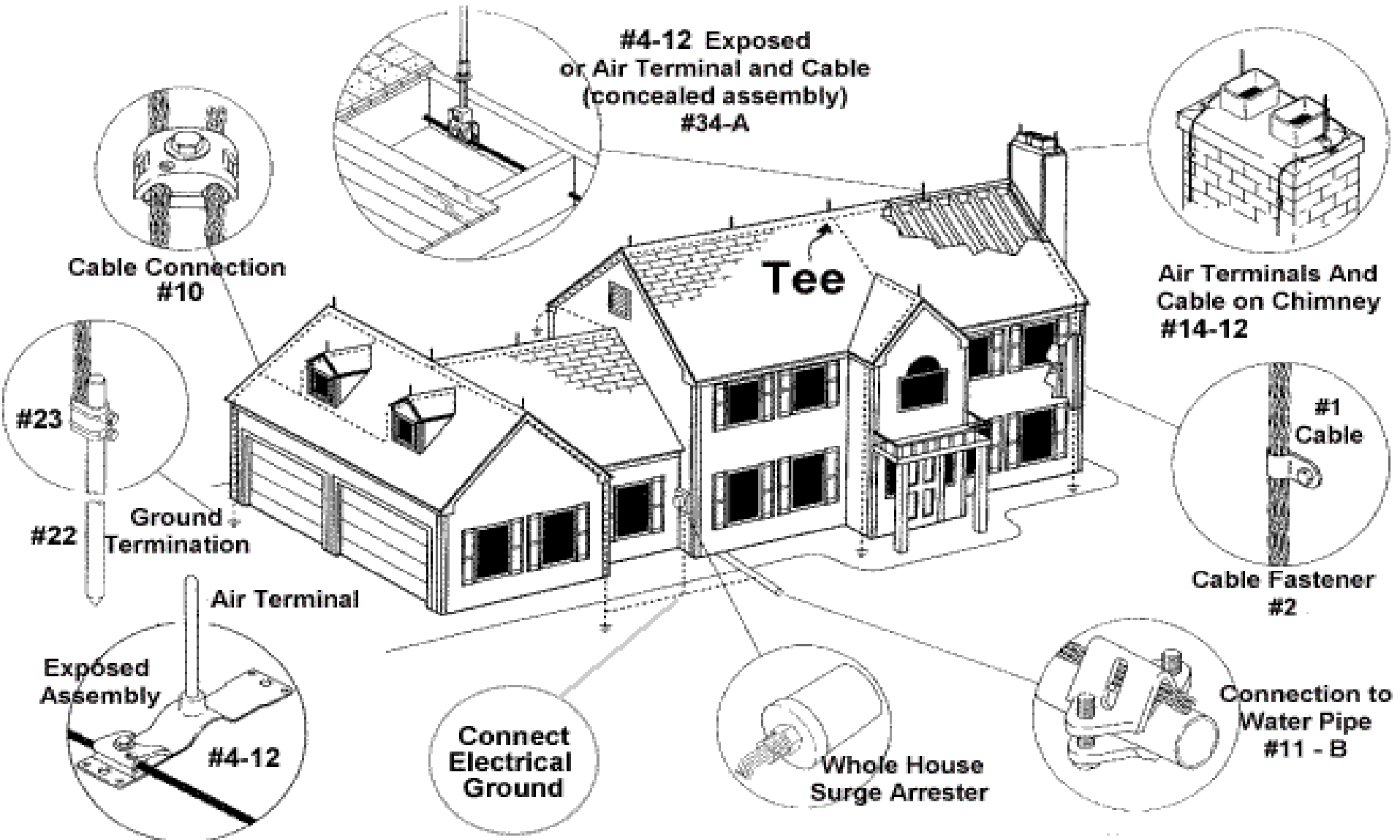

LIGHTNING SAFETY

LIGHTNING ARRESTERS



Lightning strike

From Wikipedia, the free
encyclopedia

Thanks To



WIKIPEDIA
The Free Encyclopedia

A **lightning strike** is an electric discharge between the atmosphere and an earth-bound object.^[*citation needed*] They mostly originate in a cumulonimbus cloud and terminate on the ground, called cloud to ground (CG) lightning. A less common type of strike, called ground to cloud (GC), is upward propagating lightning initiated from a tall grounded object and reaches into the clouds. About 25% of all lightning events worldwide are strikes between the atmosphere and earth-bound objects. The bulk of lightning events are intra-cloud (IC) or cloud to cloud (CC), where discharges only occur high in the atmosphere.

A single lightning event is a "flash", which is a complex, multi-stage process, some parts of which are not fully understood. Most cloud to ground flashes only "strike" one physical location, referred to as a "termination". The primary conducting channel, the bright coursing light that may be seen and is called a "strike", is only about one inch in diameter, but because of its extreme brilliance, it often looks much larger to the human eye and in photographs. Lightning discharges are typically miles long, but certain types of horizontal discharges can be upwards of tens of miles in length. The entire flash lasts only a fraction of a second. Most of the early formative and propagation stages are much dimmer and not visible to the human eye

Panorama photography taken during a lightning storm over Bucharest, Romania



Strikes

Lightning strikes can injure humans in several different ways

- **Direct**
- Direct strike – the person is part of the flash channel. Enormous quantities of energy pass through the body very quickly and this can result in internal burns and organ damage, explosions of flesh and bone, and a damaged nervous system. Depending on the flash strength and access to medical services, it may be instantaneously fatal or cause permanent injuries and impairments.
- Contact injury – the person was touching an object, generally a conductor, that is electrified by the strike.
- Side splash – branches form "jumping" from the primary flash channel, electrifying the person.
- Blast injuries – being thrown and suffering blunt force trauma from the shock wave (if very close) and possible hearing damage from the thunder.[citation needed]

- # Indirect

- Ground current or "step potential" – Earth surface charges race towards the flash channel during discharge. Due to the high impedance of the ground, the current "chooses" a better conductor, often a person's legs, passing through the body. The near instantaneous rate of discharge causes a potential (difference) over distance, which may amount to several thousand volts per linear foot. This phenomenon is responsible for more injuries and deaths than the above three combined, with reports such as "hundreds of reindeer killed by a lightning storm..." being a classic example.
- EMPs – the discharge process produces an electromagnetic pulse (EMP) which may damage an artificial pacemaker, or otherwise affect normal biological processes

- Secondary or resultant

- Explosions

- Fires

- Accidents

Injuries

Main article: Lightning injuries

Lightning strikes can produce severe injuries, and have a mortality rate of between 10% and 30%, with up to 80% of survivors sustaining long-term injuries.[3] These severe injuries are not usually caused by thermal burns, since the current is too brief to greatly heat up tissues;[citation needed] instead, nerves and muscles may be directly damaged by the high voltage producing holes in their cell membranes, a process called electroporation.[citation needed]

In a direct strike, the electrical currents in the flash channel pass directly through the victim. The relatively high voltage drop around poorer electrical conductors (such as a human being), causes the surrounding air to ionize and break down, and the external flashover diverts most of the main discharge current so that it passes "around" the body, reducing injury.

Metallic objects in contact with the skin may "concentrate" the lightning's energy, given it is a better natural conductor and the preferred pathway, resulting in more serious injuries, such as burns from molten or evaporating metal. At least two cases have been reported where a strike victim wearing an iPod suffered more serious injuries as a result.

However, during a flash, the current flowing through the channel and around the body will generate large electromagnetic fields and EMPs, which may induce electrical transients (surges) within the nervous system or pacemaker of the heart, upsetting normal operations. This effect might explain cases where cardiac arrest or seizures followed a lightning strike that produced no external injuries. It may also point to the victim not being directly struck at all, but just being very close to the strike termination.

Another effect of lightning on bystanders is to their hearing. The resulting shock wave of thunder can damage the ears. Also, electrical interference to telephones or headphones may result in damaging acoustic noise.

Epidemiology

One estimate is that 24,000 people are killed by lightning strikes around the world each year and about 240,000 are injured. Another estimate is that the annual global death toll is 6,000.

According to the NOAA, over the last 20 years, the United States averaged 51 annual lightning strike fatalities, placing it in the second position, just behind floods for deadly weather. In the US, between 9% and 10% of those struck die, for an average of 40 to 50 deaths per year (28 in 2008). The chance of an average person living in the US being struck by lightning in a given year is estimated at 1 in 960,000



TO THE MEMORY OF
WILLIAM BACON,
OF THE SALT OFFICE, LONDON, GENT.
WHO WAS KILLED BY THUNDER & LIGHTNING
AT HIS WINDOW JULY 12th 1787,
AGED 34 YEARS.

*BY TOUCH ETHEREAL IN A MOMENT SLAIN,
HE FEEL THE POWER OF DEATH BUT NOT THE PAIN*

Memorial to a lightning victim in 1787 in London in a window

In Kisii in western Kenya, some 30 people die each year from lightning strikes. Kisii's high rate of lightning fatalities occurs because of the frequency of thunderstorms and because many of the area's structures have metal roofs.

These statistics do not reflect the difference between direct strikes, where the victim was part of the lightning pathway; indirect effects of being close to the termination point, like ground currents; and resultant, where the casualty arose from subsequent events, such as fires or explosions. Even the most knowledgeable first responders may not recognize a lightning related injury, let alone particulars, which a medical examiner, police investigator or on the rare occasion a trained lightning expert may have difficulty identifying to record accurately. This ignores the reality that lightning, as the first event, may assume responsibility for the overall and resulting accident.[citation needed]

Direct strike casualties could be much higher than reported numbers

Effect on nature

Impact on vegetation

Trees are frequent conductors of lightning to the ground. Since sap is a relatively poor conductor, its electrical resistance causes it to be heated explosively into steam, which blows off the bark outside the lightning's path. In following seasons trees overgrow the damaged area and may cover it completely, leaving only a vertical scar. If the damage is severe, the tree may not be able to recover, and decay sets in, eventually killing the tree.

In sparsely populated areas such as the Russian Far East and Siberia, lightning strikes are one of the major causes of forest fires. The smoke and mist expelled by a very large forest fire can cause electric charges, starting additional fires many kilometers downwind



A green tree which was struck by lightning,
exploding the trunk

Shattering of rocks

When water in fractured rock is rapidly heated by a lightning strike, the resulting steam explosion can cause rock disintegration and shift boulders. It may be a significant factor in erosion of tropical and subtropical mountains that have never been glaciated. Evidence of lightning strikes includes erratic magnetic fields.

Electrical and structural damage

A sculpture damaged by lightning in Wellington, New Zealand

The Eiffel Tower as a colossal lightning conductor. Photograph taken 1902-06-03 21:02

Telephones, modems, computers and other electronic devices can be damaged by lightning, as harmful overcurrent can reach them through the phone jack, Ethernet cable, or electricity outlet. Close strikes can also generate electromagnetic pulses (EMPs) – especially during "positive" lightning discharges.

Lightning currents have a very fast rise time, on the order of 40 kA per microsecond. Hence, conductors of such currents exhibit marked skin effect, causing most of the currents to flow through the outer surface of the conductor.

In addition to electrical wiring damage, the other types of possible damage to consider include structural, fire, and property damage.



A eucalyptus tree that was struck by lightning, while two nearby pine trees were untouched, Darwin, Northern Territory, Australia

Prevention and mitigations

The field of lightning protection systems is an enormous industry worldwide due to the impacts lightning can have on the constructs and activities of humankind. Lightning, as varied in properties measured across orders of magnitude as it is, can cause direct effects or have secondary impacts; lead to the complete destruction of a facility or process or simply cause the failure of a remote electronic sensor; it can result in outdoor activities being halted for safety concerns to employees as a thunderstorm nears an area and until it has sufficiently passed; it can ignite volatile commodities stored in large quantities or interfere with the normal operation of a piece of equipment at critical periods of time. The impacts of a lightning event are as varied and far reaching as the nearly infinite products and systems devised to mitigate the effects of lightning on our lives.[citation needed]



A sculpture damaged by lightning
in Wellington, New Zealand

Most lightning protection devices and systems protect physical structures on the earth, aircraft in flight being the notable exception, however some attention has been paid to attempting to control lightning in the atmosphere, however all the attempts proved extremely limited in success. Chaff and silver iodide crystal concepts were devised to deal directly with the cloud cells and were dispensed directly into the clouds from an overflying aircraft. The chaff was devised to deal with the electrical manifestations of the storm from within, while the silver iodide salting technique was devised to deal with the mechanical forces of the storm

Lightning protection systems

- Main article: Lightning rod
- See also: Lightning arrester and Surge protector
- Hundreds of devices, including lightning rods and charge transfer systems, are used to mitigate lightning damage and influence the path of a lightning flash.



The Eiffel Tower as a colossal lightning conductor. Photograph taken 1902-06-03 21:02

A lightning rod (or lightning protector) is a metal strip or rod connected to earth through conductors and a grounding system, used to provide a preferred pathway to ground if lightning terminates on a structure. The class of these products are often called a "finial" or "air terminal". A lightning rod or "Franklin rod" in honor of its famous inventor, Benjamin Franklin, is simply a metal rod, and without being connected to the lightning protection system, as was sometimes the case in the old days, will provide no added protection to a structure. Other names include "lightning conductor", "arrester", and "discharger"; however, over the years these names have been incorporated into other products or industries with a stake in lightning protection. Lightning arrester, for example, often refers to fused links that explode when a strike occurs to a high voltage overhead power line to protect the more expensive transformers down the line by opening the circuit. In reality, it was an early form of a heavy duty surge protection device (SPD). Modern arresters, constructed with metal oxides, are capable of safely shunting abnormally high voltage surges to ground while preventing normal system voltages from being shorted to ground.

Monitoring and warning systems

The exact location of a lightning strike or when it will occur is still impossible to predict. However, products and systems have been designed of varying complexities to alert people as the probability of a strike increases above a set level determined by a risk assessment for the location's conditions and circumstances. One significant improvement has been in the area of detection of flashes through both ground and satellite-based observation devices. The strikes and atmospheric flashes are not predicted, however the level of detail recorded by these technologies has vastly improved in the past 20 years.

Although commonly associated with thunderstorms at close range, lightning strikes can occur on a day that seems devoid of clouds. This occurrence is known as "A Bolt From the Blue"; lightning can strike up to 10 miles from a cloud.

An example
of a
standard,
pointed-tip,
air terminal.



Lightning interferes with AM (amplitude modulation) radio signals much more than FM (frequency modulation) signals, providing an easy way to gauge local lightning strike intensity. To do so, one should tune a standard AM medium wave receiver to a frequency with no transmitting stations, and listen for crackles amongst the static. Stronger or nearby lightning strikes will also cause cracking if the receiver is tuned to a station. As lower frequencies propagate further along the ground than higher ones, the lower medium wave (MW) band frequencies (in the 500–600 kHz range) can detect lightning strikes at longer distances; if the longwave band (153–279 kHz) is available, using it can increase this range even further.

Lightning detection systems have been developed and may be deployed in locations where lightning strikes present special risks, such as public parks. Such systems are designed to detect the conditions which are believed to favor lightning strikes and provide a warning to those in the vicinity to allow them to take appropriate cover.

A Thor Guard lightning prediction system



Personal safety

The U.S. National Lightning Safety Institute advises American citizens to have a plan for their safety when a thunderstorm occurs and to commence it as soon as the first lightning or thunder is observed. This is important as lightning can strike without rain actually falling. If thunder can be heard at all, then there is a risk of lightning. The safest place is inside a building or a vehicle. Risk remains for up to 30 minutes after the last observed lightning or thunder.

The National Lightning Safety Institute recommends using the F-B (flash to boom) method to gauge distance to a lightning strike. The flash of a lightning strike and resulting thunder occur at roughly the same time. But light travels 300,000 kilometers in a second, almost a million times the speed of sound. Sound travels at the slower speed of 344 m/s, so the flash of lightning is seen before thunder is heard. To use the method, count the seconds between the lightning flash and thunder. Divide by three to determine the distance in kilometers, or by five for miles. Immediate precautions against lightning should be taken if the F-B time is 25 seconds or less, that is, if the lightning is closer than 8 km (5.0 mi).

Reports differ regarding what to do if caught outside during a storm. One study shows that prostration is safer than lying down flat when there are no other alternatives.

A contrasting report suggested that it did not matter whether a person was standing up, squatting, or lying down when outside during a thunderstorm, because lightning can travel along the ground; this report suggested it was safest to be inside a solid structure or vehicle. In the United States, the average annual death toll from lightning is 51 deaths per year, although there were only 23 deaths in 2013, which was a record low; the riskiest activities include fishing, boating, camping, and golf. A person injured by lightning does not carry an electrical charge, and can be safely handled to apply first aid before emergency services arrive. Lightning can affect the brainstem, which controls breathing.

Several studies conducted in South Asia and Africa suggest that the dangers of lightning are not taken sufficiently seriously there. A research team from the University of Colombo found that even in neighborhoods which had experienced deaths from lightning, no precautions were taken against future storms. An expert forum convened in 2007 to address how to raise awareness of lightning and improve lightning protection standards, and expressed concern that many countries had no official standards for the installation of lightning rods.

• Notable incidents

- All events associated or suspected of causing damage are called "lightning incidents" due to four important factors.
- Forensic evidence of a lightning termination, in the best investigated examples, are minuscule (a pit in metal smaller than a pen point) or inconclusive (dark coloration).
- The object struck may explode or subsequent fires destroy all of the little evidence that may have been available immediately after the strike itself.

- The flash channel and discharge itself are not the only causes of injury, ignition or damages, i.e., ground currents or explosions of flammables.
- Human sensory acuity is not as fine as that of the milliseconds duration of a lightning flash, and our ability to observe this event is subject to the brain's inability to comprehend it. Lightning detection systems are coming online, both satellite and land based, however their accuracy is still measured in the hundreds to thousands of feet, rarely allowing them to pinpoint the exact location of the termination.[citation needed]

As such it is often inconclusive, albeit highly probably a lightning flash was involved, hence categorizing it as a "lightning incident" covers all bases.

Earth-bound

- 1660s: In 1660, lightning ignited the gunpowder magazine at Osaka Castle, Japan; the resultant explosion set the castle on fire. In 1665, lightning again terminated on the main tower of the castle, igniting a fire which subsequently burned it to its foundation.
- 1769: A particularly deadly lightning incident occurred in Brescia, Italy. Lightning struck the Church of St. Nazaire, igniting the 90 tonnes of gunpowder in its vaults; the resulting explosion killed 3,000 people and destroyed a sixth of the city.[28]
- 1902: A lightning strike damaged the upper section of the Eiffel Tower, requiring the reconstruction of its top[29]
- 1970 July 12: The central mast of the Orlunda radio transmitter in central Sweden collapsed after a lightning strike destroyed its foundation insulator.

- 1994 November 2: A lightning incident led to the explosion of fuel tanks in Dronka, Egypt, causing 469 fatalities.
- 2005 October 31: Sixty-eight dairy cows, all full of milk, died on a farm at Fernbrook on the Waterfall Way near Dorrigo, New South Wales, after being involved in a lightning incident. Three others were temporarily paralyzed for several hours, later making a full recovery. The cows were sheltering near a tree when it was struck by lightning and the ground potential followed the path of least resistance through the animals' bodies.
- 2007 July: A lightning incident killed up to 30 people when it struck Ushari Dara, a remote mountain village in northwestern Pakistan.
- 2011 June 8: A lightning strike sent 77 Air Force cadets to the hospital when it struck in the middle of a training camp at Camp Shelby, Mississippi.
- 2013 February: Nine South African children were hospitalized after a lightning incident occurred on a cricket field at their school, injuring five children on the pitch and four girls who were walking home.

- 2016 May–June: Rock am Ring festival near Frankfurt was cancelled after at least 80 people were injured due to lightning in the area. Additionally 11 children in France and three adults in Germany were injured and one man killed in southern Poland around the same dates.
- 2016 August 26: A herd of wild reindeer was struck on the Hardangervidda in central Norway, killing 323. Norwegian Environment Agency spokesman Kjartan Knutsen said it had never heard of such a death toll before. He said he didn't know if multiple strikes occurred, but that they all died in "one moment".

In-flight

- 1963 December 8: Pan Am Flight 214 crashed outside Elkton, Maryland, during a severe electrical storm, with a loss of all 81 passengers and crew. The Boeing 707-121, registered as N709PA, was on the final leg of a San Juan–Baltimore–Philadelphia flight.
- 1969 November 14: The Apollo 12 mission's Saturn V rocket and its ionized exhaust plume became part of a lightning flash channel 36.5 seconds after lift-off. Although the discharge occurred "through" the metal skin and framework of the vehicle, it did not ignite the rocket's highly combustible fuel.

- 1971 December 24: LANSA Flight 508, a Lockheed L-188A Electra turboprop, registered OB-R-941, operated as a scheduled domestic passenger flight by Lineas Aéreas Nacionales Sociedad Anonima (LANSA), crashed after a lightning strike ignited a fuel tank while it was en route from Lima, Peru, to Pucallpa, Peru, killing 91 people – all of its 6 crew-members and 85 of its 86 passengers. The sole survivor was Juliane Koepcke, who fell 2 miles (3.2 km) down into the Amazon rainforest strapped to her seat and remarkably survived the fall, and was then able to walk through the jungle for 10 days until she was rescued by local lumbermen.
- 2012 November 4: there were reports of a plane exploding off the coast of Herne Bay, Kent, while in flight. This did not turn out to be the case, rather the plane became part of the flash channel, causing observers to report the plane and surrounding sky appeared bright pink.[38]

MOST-STRIKEN human

Roy Sullivan holds a Guinness World Record after surviving seven different lightning strikes over 35 years. He had multiple injuries across his body.

Lightning arrester

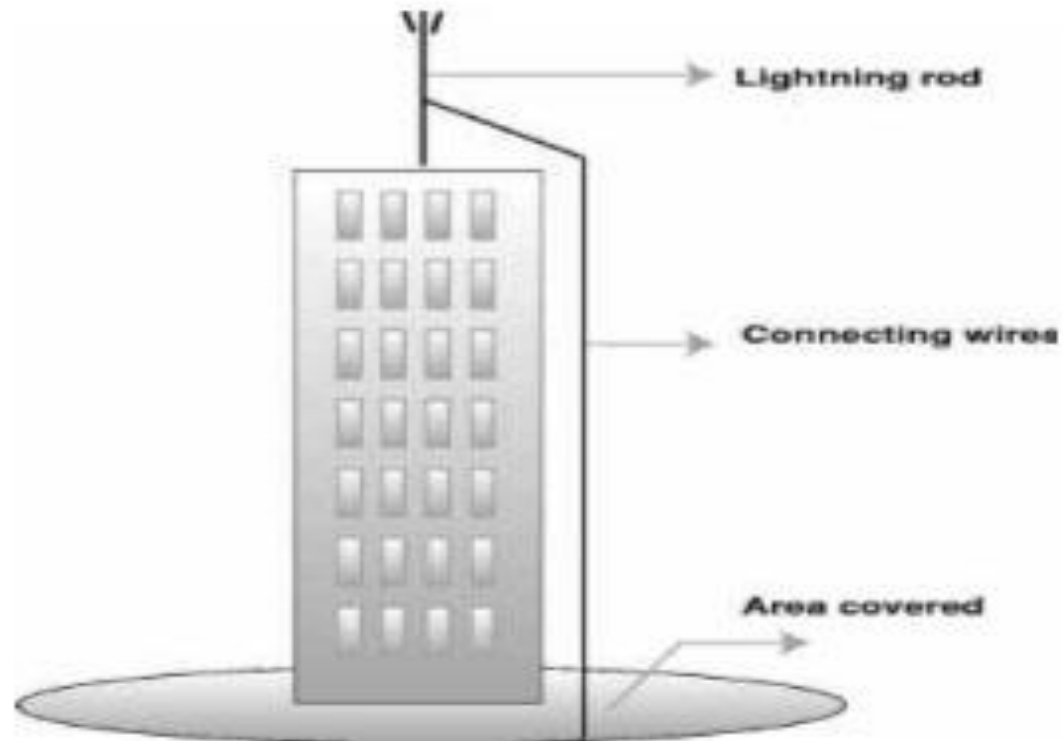

LIGHTENING SAFETY

QUESTION: How does a lightning arrester work?

G. Dhanabalan, Nagapattinam, T.N.

ANSWER 1: Lightning, is a form of visible discharge of electricity between rain clouds or between a rain cloud and the earth. The electric discharge is seen in the form of a brilliant arc, sometimes several kilometres long, stretching between the discharge points. How thunderclouds become charged is not fully understood, but most thunderclouds are negatively charged at the base and positively charged at the top. However formed, the negative charge at the base of the cloud induces a positive charge on the earth beneath it, which acts as the second plate of a huge capacitor.

When the electrical potential between two clouds or between a cloud and the earth reaches a sufficiently high value (about 10,000 V per cm or about 25,000 V per in), the air becomes ionized along a narrow path and a lightning flash results.

Many meteorologists believe that this is how a negative charge is carried to the ground and the total negative charge of the surface of the Earth is maintained.

The possibility of discharge is high on tall trees and buildings rather than to ground. Buildings are protected from lightning by metallic lightning rods extending to the ground from a point above the highest part of the roof. The conductor has a pointed edge on one side and the other side is connected to a long thick copper strip which runs down the building. The lower end of the strip is properly earthed. When lightning strikes it hits the rod and current flows down through the copper strip. These rods form a low-resistance path for the lightning discharge and prevent it from travelling through the structure itself. — The Hindu S & T Desk

LIGHTENING SAFETY

Thanks : The Hindu

QUESTION: How does a lightning arrester work?

ANSWER 2: The lightning arrester protects the structure from damage by intercepting flashes of lightning and transmitting their current to the ground. Since lightning strikes tends to strike the highest object in the vicinity, the rod is placed at the apex of a tall structure. It is connected to the ground by low-resistance cables. In the case of a building, the soil is used as the ground, and on a ship, water is used. A lightning rod provides a cone of protection, which has a ground radius approximately, equal to its height above the ground.

C. Srinivasan, Hyderabad, A. P.

LIGHTENING SAFETY

It is your TURN

Do brainstorming on this aspect of safety with other members of the family and get ideas from them. After all everyone has knowledge and experience

The session will make them think and will ensure their contribution & involvement.

Add inputs emerging out of brainstorming
done with your family / colleagues.
Practise them , Do send the same to
exnora@gmail.com

There are more kinds
of SAFETY which are
all needed for happy,
peaceful & long life.

Please see next

<p>SAFIRST LIFE 27 sets of do-how on various types of Safety</p>	<p>Safety World Think Safety & Act Safely Safety-First is "SAFIRSTY" Safety ExNoRa</p>	<p>Safety + First 27 sets of do-how on various types of Safety</p>
<p><u>Home Safety</u> All READ as SAFETY FROM....</p>	<p><u>Personal & Property Safety</u></p>	<p><u>Natural Calamities Safety</u></p>
<p>Air Safety</p>	<p>Burglary Safety</p>	<p>Cyclone Safety</p>
<p>Water Safety</p>	<p>Child Safety</p>	<p>Earthquake Safety</p>
<p>Food Safety</p>	<p>Woman Safety</p>	<p>Tsunami Safety</p>
<p>Electricity Safety</p>	<p>Lift Safety</p>	<p>Lightening Safety</p>
<p>Fire Safety</p>	<p>Travel Safety</p>	<p>Flood Safety</p>
<p>Gas Safety</p>	<p>Road Safety</p>	<p>Land Slide /Slip Safety</p>
<p>Pests Safety</p>	<p>School Van Safety</p>	<p>Neighbourhood safety</p>
<p>Bacteria Safety</p>	<p>Cyber Crimes Safety</p>	<p>Riot Safety</p>
<p>Indoor Pollution Safety</p>	<p>Area Safety</p>	<p>Industrial Pollution Safety</p>

THERE ARE 3 OPTIONS OF IMPLEMENTING **SAFETY LOFTY**

which will include **LIGHTENING SAFETY**
& other kinds of **SAFETY**

1. As an activity of your **ExNoRa** INNOVATORS CLUB
2. as an activity of Residents **Welfare Association (RWA)** or RWA **ExNoRa**
3. as an independent activity of the people who need the service in which case that will function as a **SATELLITE ORGANISATION** of **ExNoRa** INNOVATORS CLUB of the **PLACE / TOWN / INSTITUTION**

WEBSITES

PPTs

DVDs

YouTube &
FLASH

E BOOKS &
E BROCHURES

ONLINE
COMMUNITIES

CONTACT DETAILS :

Exn Dr. Nirmal Basu **GPian**
7th SENSE MASTER &
Founder, **ExNoRa** INNNOVATORS
INTERNATIONAL

+91 98400 34900

+ 91 44 2363 8383

www.7thsense.guru

exnora@gmail.com

www.exnorainnovators.club www.exnora-innovators.club

facebook

twitter™

LinkedIn®

You
Tube

[www.facebook.com/
nirmal.exnora](http://www.facebook.com/nirmal.exnora)

[twitter.com
/mbnirmal](https://twitter.com/mbnirmal)

[www.linkedin.
com/in/mbnir
mal](http://www.linkedin.com/in/mbnirmal)

SEARCH
Nirmal MB

